

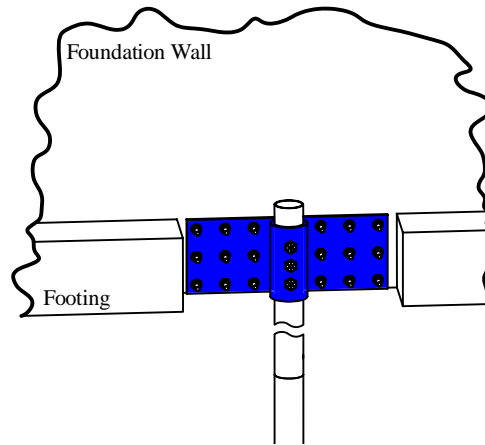

### Application View



# PLATE BRACKET

P/N: MP1001

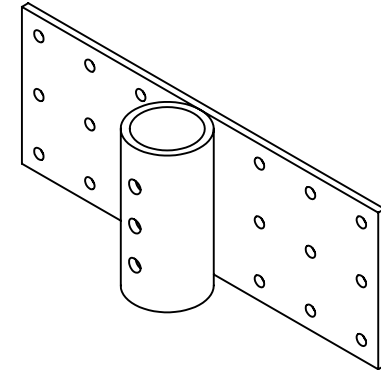

The patented heavy duty Magnum Plate Bracket is mounted to the face of a footing or foundation wall using up to 18 concrete wedge anchors. This bracket design minimizes the eccentricity forces applied to the foundation wall during the underpinning process. This bracket is compatible with Magnum 3" O.D. 1/8" wall & 1/4" wall structural tubing products for both Steel Push Pier & Helix Foundation Systems.

Note: All dimensions are in inches and shown for reference only. For product specific Engineering Drawings, please contact Magnum Piering Engineering Department.

### Product Specification

**Material:**

Plate to be ASTM A-36 or better; minimum yield strength of 36 KSI.

Tube to be ASTM A513 T5 or better; minimum yield strength of 70 KSI

**Weld:** 70 KSI minimum yield

**Product Weight:** 27 lbs

**Covered under**  
US Patent # 5,234,287

**Capacity:**

See Magnum Steel Push Piering Technical Reference Manual for specific capacity information.

