

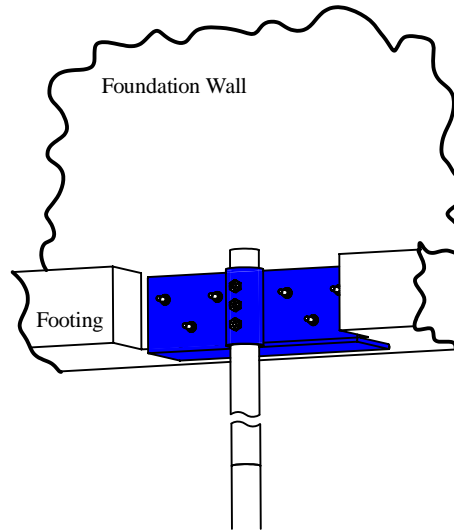

Application View



ANGLE BRACKET

P/N: MP1002

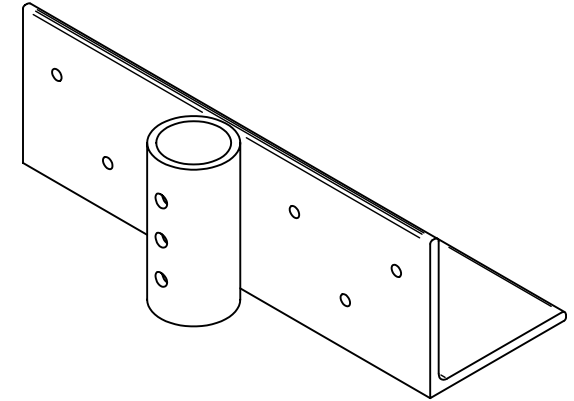

The heavy duty Magnum Angle Bracket is mounted to the face and beneath the bottom of a footing or foundation wall using up to 6 concrete wedge anchors. This bracket design minimizes the eccentricity forces applied to the foundation wall during the underpinning process. This bracket is compatible with Magnum 3" O.D. 1/8" wall & 1/4" wall structural tubing products for both Steel Push Pier & Helix Foundation Systems.

Note: All dimensions are in inches and shown for reference only. For product specific engineering drawings, please contact Magnum Piering Engineering Department.

Product Specification

Material:

Angle to be ASTM A-36 or better; minimum yield strength of 36 KSI .

Tube to be ASTM A513 T5 or better; minimum yield strength of 70 KSI

Weld: 70 KSI minimum yield

Product Weight: 62 lbs

Capacity:

See Magnum Steel Push Piering Technical Reference Manual for specific capacity information.

