

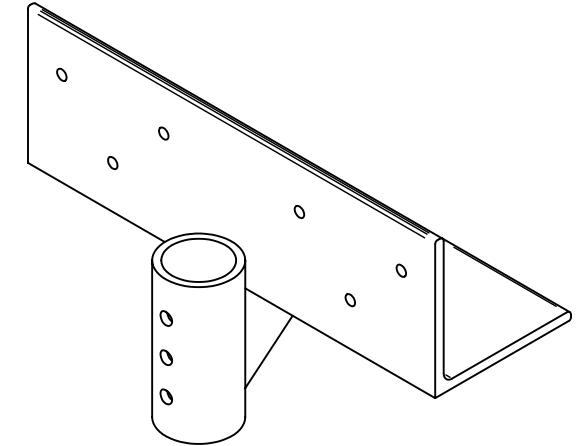

GUSSETED ANGLE BRACKET

P/N: MP1005

Application View

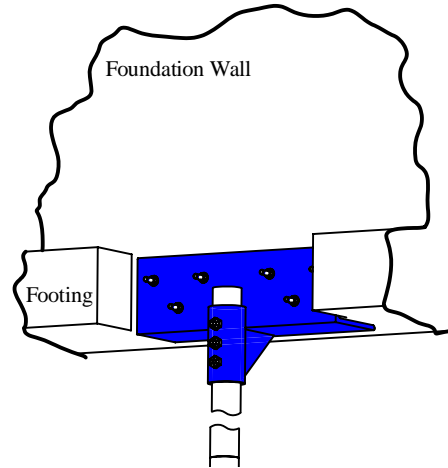

The heavy duty Magnum Gusseted Angle Bracket is mounted to the face and beneath the bottom of a footing or foundation wall using up to 6 concrete wedge anchors. This bracket design minimizes the eccentricity forces applied to the foundation wall during the underpinning process. This bracket is compatible with Magnum 3" O.D. 1/8" wall & 1/4" wall structural tubing products for both Steel Push Pier & Helix Foundation Systems.

Note: All dimensions are in inches and shown for reference only. For product specific Engineering Drawings, please contact Magnum Piering Engineering Department.

Product Specification

Material:

Plate to be ASTM A-36 or better; minimum yield strength of 36 KSI.

Tube to be ASTM A513 T5 or better; minimum yield strength of 70 KSI

Weld: 70 KSI minimum yield

Product Weight: 66 lbs

Capacity:

See Magnum Steel Push Piering Technical Reference Manual for specific capacity information.

