

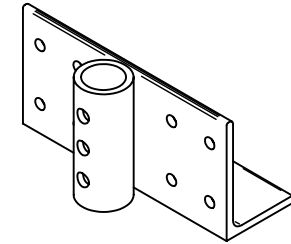

## Application View

# LD ANGLE BRACKET

P/N: MP2002

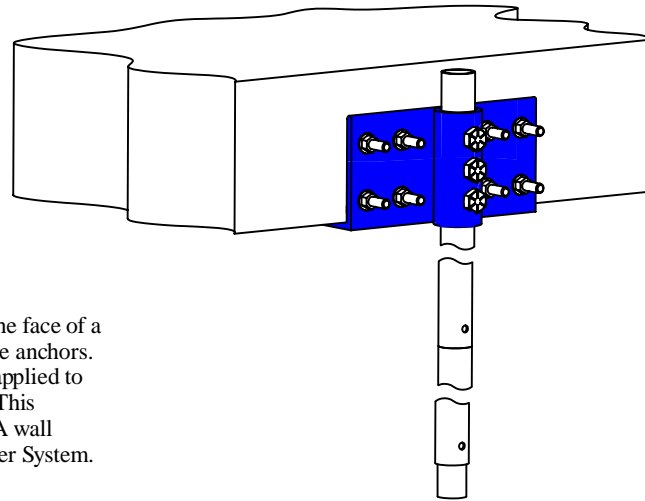

The light duty Magnum Angle Bracket is mounted to the face of a footing or foundation wall using up to 8 concrete wedge anchors. This bracket design minimizes the eccentricity forces applied to the foundation wall during the underpinning process. This bracket is compatible with Magnum 1 3/4" O.D. 11 GA wall structural tubing products for Light Duty Steel Push Pier System.

Note: All dimensions are in inches and shown for reference only. For product specific engineering drawings, please contact Magnum Piering Engineering Department.

### Product Specification

**Material:**

Angle to be ASTM A-36 or better; minimum yield strength of 36 KSI .

Tube to be ASTM A513 T5 or better; minimum yield strength of 70 KSI

**Weld:** 70 KSI minimum yield

**Product Weight:** 16 lbs

**Capacity:**

See Magnum Steel Push Piering Technical Reference Manual for specific capacity information.

