

# Magnum® Helical Pier Foundation Repair System™ with MP 1001 Patented Plate Bracket

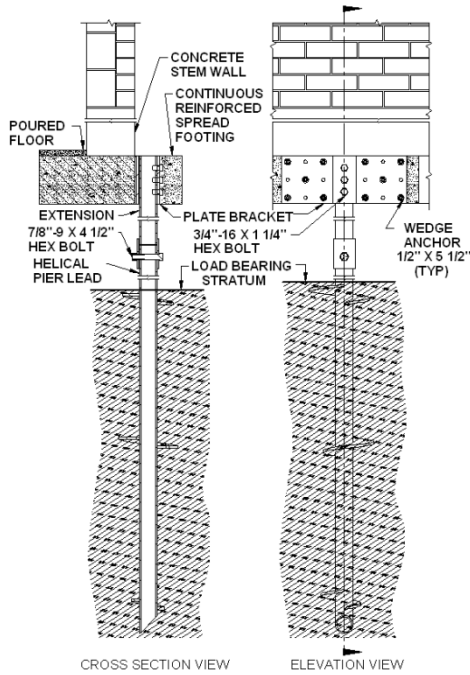

- Pre-engineered system for lifting and/or stabilizing single & multi-story structures
- Each installed pier is full-scale load tested
- 106,000 lb. maximum capacity; 53,000 lbs. with 2.0 safety margin (see table below)
- Magnum Plate Bracket steel & weld specifications
  - 21" long x 8" high
  - plate steel ASTM A-36, 3600 yield
  - tube steel ASTM A-513, 70,000 tensile, 65,000 yield
- Magnum 3" O.D. high-strength steel tubing ASTM A-513
  - 65,000 min. tensile & 75,000 min. yield
  - .125" standard wall thickness
  - .250" heavy-duty wall thickness
- Bracket & pier tubing available as bare metal or optional hot-dip galvanized
- Pier installation using Magnum MP6000 hydraulic ram system

U.S. Patent #5,234,287 MP1001 Plate Bracket

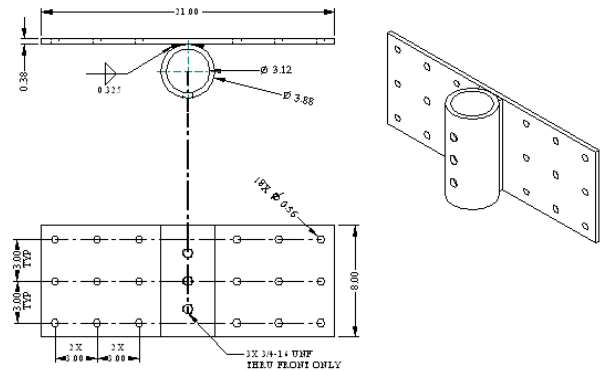
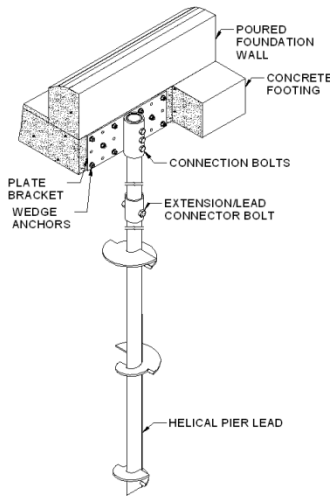

## Magnum Helical Pier Capacities with MP 1001 Patented Plate Bracket

Connection Type	Pier Tube Size (STD)	Ultimate Capacity	Allowable Capacity (2.0 Factor of Safety)	Pier Tube Size (HD)	Ultimate Capacity	Allowable Capacity (2.0 Factor of Safety)
Single Bolted	.125 Wall	20 kips	10 kips	.250 Wall	36 kips	18 kips
Double Bolted	.125 Wall	34 kips	17 kips	.250 Wall	70 kips	35 kips
Triple Bolted	.125 Wall	57 kips	28 kips	.250 Wall	106 kips	53 kips

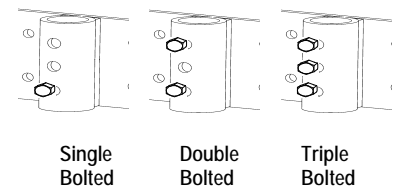

Capacities shown are for the bracket and its connection to the pile. Connection to the structure depends on strength of existing concrete, reinforcing steel, and number of anchor bolts and should be designed by an engineer or load tested. Capacity of the system may be limited by the helical pile; consult Magnum helical pile specifications for information on maximum helical pile capacities.