

MAGNUM[®] MHL425BR (Reinforced) Xtreme Duty[™] Helical Piles

105 Ton End Bearing - 80 Ton from Torque

High-Strength 4.5" Diameter, 0.25" Wall, Round-Shaft

Helical Piles with Rigid Coupler & (2) 1.25" Bolts



Description

Magnum[®] MHL425BR Xtreme Duty[™] Helical Piles have 80 tons ultimate capacity from torque and 40 tons working capacity in compression and tension. Lead sections and extensions couple together to extend helical blades to the desired bearing stratum. Round shafts offer increased lateral and buckling resistance compared to solid square shafts. Galvanized coating extends average life expectancy to over 100 years for most soil conditions. Patented Magnum[®] Dual-Cutting Edge Blades (DCE) enhance penetration through dense soils with occasional cobbles and debris. Custom lengths and blade configurations are available upon request. See Magnum[®] Technical Manual for additional information.

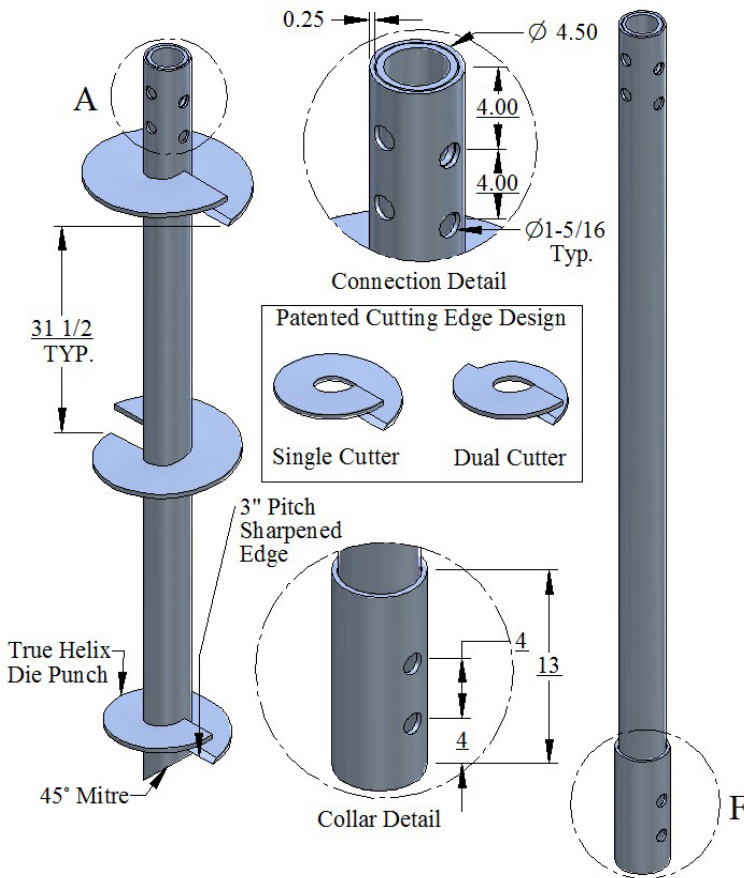

Lead - MHL425BR7B10S12S14SG

Extension - MHE425BR7G

4.5" Product Line Helix Blade Specifications & Available Configurations

0.625" Thick; ASTM A36 or Higher

3" Blade Pitch

10", 12", 14", 16" Diameter

Standard Circular Blade, or

Patented Dual Cutting Edge

Sharpened Edges - All Blades

* 4 ft. Lead or Extension - up to 2 blades

* 7 ft. Lead or Extension - up to 3 blades

* 10 ft. Lead or Extension - up to 4 blades

* 18 ft. Lead or Extension - up to 7 blades

* **Standard Stocking Length**

STEEL SPECIFICATIONS	
SHAFT	HSS 4.50 x 0.25 wall ASTM A450 65 KSI, or Equiv.
I	7.33 in ⁴
Ag	3.24 in ²
S	3.27 in ³
COUPLING	0.31" Wall Collar with 0.25" Insert
BOLTS	(2) 1.25" Diameter SAE Grade 5
BLADES	0.625" Thick, Helix Die-Pressed ASTM A36, or Better
COATING	Hot-Dip Galvanized to ASTM A153

CAPACITIES	
5.7 ft ⁻¹	Ultimate Capacity-to-Torque Ratio
28,000 ft-lbs	Maximum Torsional Strength
END BEARING - COMPRESSION	
105 Tons	Ultimate End Bearing Capacity
53 Tons	Allowable End Bearing Capacity
BY TORQUE - COMPRESSION & TENSION	
80 Tons	Ultimate Compression & Tension
40 Tons	Allowable Compression & Tension

Note: Helical piles shall be installed to appropriate depth into suitable bearing stratum as determined by geotechnical engineer or local practice. Maximum allowable capacity is based on installation to maximum torsional strength. Ultimate capacity is limit state. A minimum factor of safety of 2.0 is recommended for determining allowable capacity from correlations with final installation torque. Deflections of 0.5" to 1.0" are typical at allowable capacity. A higher factor of safety may be required for tolerable deflections. For tension capacity, blades must be deeply embedded. Load tests are recommended when practical.

All Magnum Steel & Products Made in U.S.A.

Magnum Piering, Inc.

6082 Schumacher Park Dr.

West Chester, OH 45069

800-822-7437

www.magnumpiering.com

© Copyright 2009 Magnum Piering, Inc. All Rights Reserved.
U.S. Patents 6,058,662 and 5,234,287; Other Patents Pending.

MHL425BR7B10S12S14SG Rev. 5-6-09