

# MAGNUM<sup>®</sup> MHC1000-3R Grade Beam Cap

Allowable Capacity - 25 Tons Compression / 25 Tons Tension

(2) No. 7, Gr. 60 Reinforcing Steel Bars Horizontal & 3-Inch I.D. Collar

Fits MH313, MH313R, MH325, MH325R\* Magnum<sup>®</sup> Helical Piles



## Description

Magnum MHC1000-3R grade beam cap has 50 tons ultimate capacity, 25 tons working capacity in compression and tension. The grade beam cap consists of a collar tube with bolt hole for connection to Magnum helical piles and horizontal reinforcing steel bars for attachment to cast-in-place concrete for new construction and foundation augmentation. The grade beam cap is designed in accordance with ICC-ES document AC358 as well as IBC, ACI, and AISC codes. Design and detailing of the structure to which the helical pile cap is attached varies by project and is the responsibility of registered design professional including minimum concrete cover for one-way shear, two-way punching shear, and bearing.

SPECIFICATIONS	
Collar Tube	0.3 in. x 3 in. I.D. ASTM A513 GR65+
End Effector	(2) #7 GR60 Bars Horizontal
Pile Connection	(2) 1" SAE GR5 / ASTM A325
Surface Coating	Galvanized per ASTM A153/A123 (G), Bare Steel (NG), or Epoxy Coated per ICC-ES AC228 (EP)
Compatibility	MH313, MH313R, MH325, MH325R*

\* Connection bolt size differs from pre-drilled hole in MH325R making field drilling of pile shaft required.

CAP CAPACITY	
Ultimate Compression / Tension	50 Tons / 50 Tons
Allowable Compression / Tension	25 Tons / 25 Tons

Note: Cap capacity takes into account strength of collar, end effector, and pile connection. Capacity may be limited by the helical pile itself, bearing/pullout capacity of soil, or strength of the structure to which the cap is attached, whichever is less.

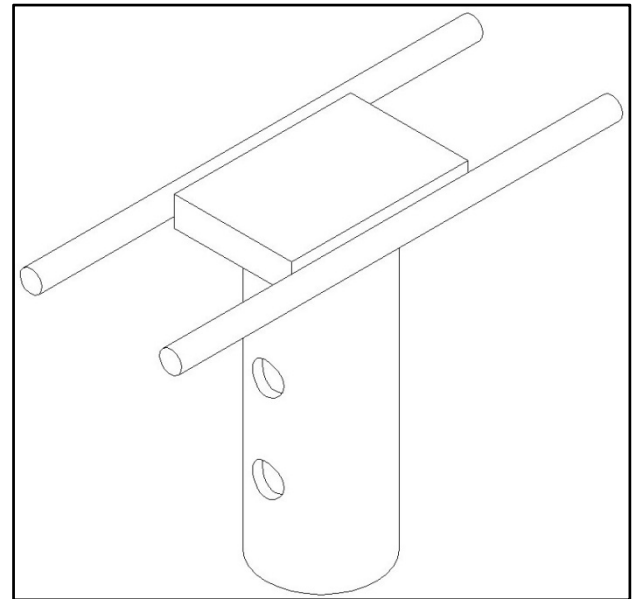

### Installation Notes:

After installation of a Magnum Helical Pile to the correct depth, torque, and capacity, begin by cutting-off the pile shaft at the proper elevation. For "B" applications, drill connection holes thru the pile shaft using a Magnum drill template. Install the pile cap, pile connection bolts, and snug-tighten nuts. For "W" applications, plug weld cap in-place using the manufactured holes in the cap collar tube. Remove coatings from surfaces prior to welding.

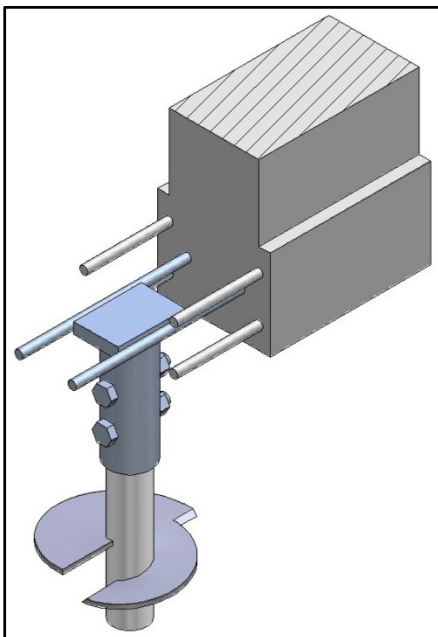

*All Magnum Steel & Products Made in U.S.A.*

### Magnum Piering, Inc.

6082 Schumacher Park Dr.  
West Chester, OH 45069  
800-822-7437  
www.magnumpiering.com

© Copyright 2010 Magnum Piering, Inc. All Rights Reserved.  
U.S. Patents 6,058,662 and 5,234,287; Other Patents Pending.