

MAGNUM[®] MHC1122-3 Wood Beam Cap

Allowable Capacity 6 Tons Compression / 6 Tons Tension

3-Inch I.D. Collar with 8"x4"x1/8" – 8" Long Angle

Fits MH313, MH313R, MH325, MH325R Magnum[®] Helical Piles



Description

Magnum MHC1122-3 wood beam cap has 12 tons ultimate capacity, 6 tons working capacity in compression and tension. The wood beam cap consists of a collar tube with bolt hole for connection to Magnum helical piles and an angle for attachment to a wood beam. This cap was designed to be used with the Magnum K-brace system for boardwalks but can be used with other wood structures. The wood beam cap is designed in accordance with ICC-ES document AC358 as well as IBC, ACI, and AISC codes. Application of the cap varies by project and is the responsibility of registered design professional including crushing strength, lateral bracing, and span of wood beam.

SPECIFICATIONS	
Collar Tube	0.3 in. x 3 in. I.D. ASTM A513 GR65+
End Effector	8"x4"x1/8" – 8" Long Angle with holes for (4) 1/2" Lags
Pile Connection	(4) Hilti EDS PAF
Surface Coating	Galvanized per ASTM A153/A123 (G), Bare Steel (NG), or Epoxy Coated per ICC-ES AC228 (EP)
Compatibility	MH313, MH313R, MH325, and MH325R

CAP CAPACITY	
Ultimate Compression / Tension	12 Tons / 12 Tons
Allowable Compression / Tension	6 Tons / 6 Tons

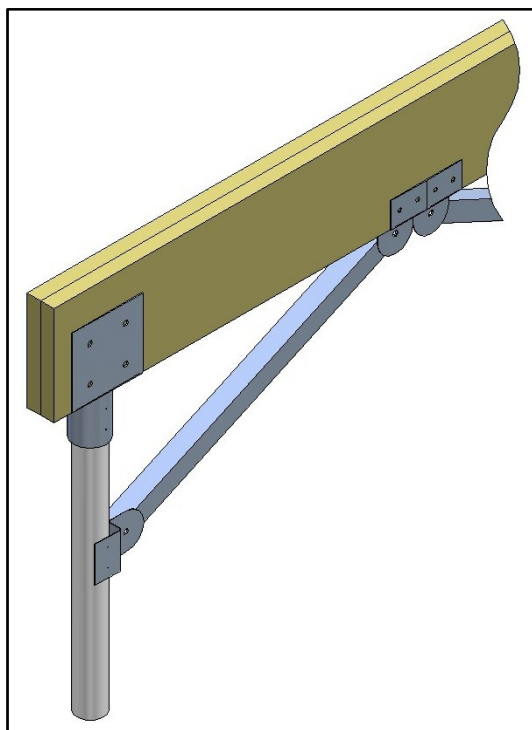
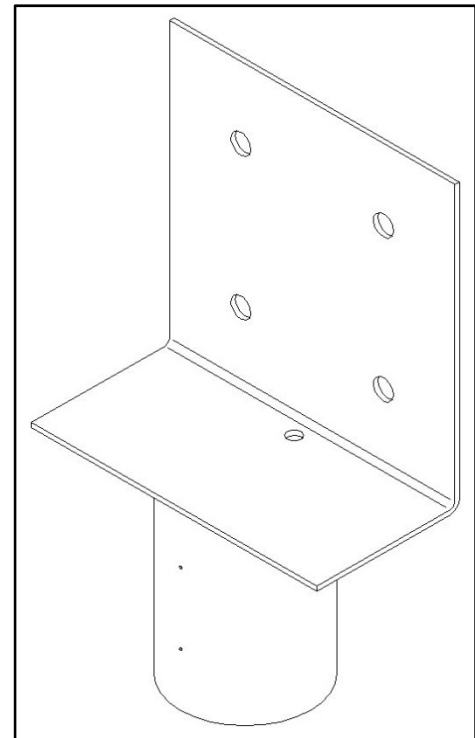

Installation Notes:

After installation of a Magnum Helical Pile to the correct depth, torque, and capacity, cut-off the pile shaft at the proper elevation. Place the pile cap over the shaft and secure with 4 Hilti EDS PAF. Place wood beam on cap angle and secure with 1/2" lag screws as required for the project. If required, install Magnum K-brace system in accordance with installation instructions for that product.

All Magnum Steel & Products Made in U.S.A.

Magnum Piering, Inc.

6082 Schumacher Park Dr.

West Chester, OH 45069

800-822-7437

www.magnumpiering.com

© Copyright 2010 Magnum Piering, Inc. All Rights Reserved.
U.S. Patents 6,058,662 and 5,234,287; Other Patents Pending.