

MAGNUM[®] MHC1123-3 Wood Beam Cap

Allowable Capacity 8 Tons Compression / 8 Tons Tension

3-Inch I.D. Collar with 8"x3.75"x1/8" – 6" Long Angle

Fits MH313, MH313R, MH325, MH325R Magnum[®] Helical Piles



Description

Magnum MHC1123-3 wood beam cap has 16 tons ultimate capacity, 8 tons working capacity in compression and tension. The wood beam cap consists of a collar tube with bolt hole for connection to Magnum helical piles and an angle for attachment to a wood beam. The wood beam cap is designed in accordance with ICC-ES document AC358 as well as IBC, ACI, and AISC codes. Application of the cap varies by project and is the responsibility of registered design professional including crushing strength, lateral bracing, and span of wood beam.

SPECIFICATIONS	
Collar Tube	0.3 in. x 3 in. I.D. ASTM A513 GR65+
End Effector	8"x3.75"x1/8" – 6" Long Angle with holes for (3) 1/2" Lags
Pile Connection	(1) 7/8" SAE Grade 5 / ASTM A325 Bolt
Surface Coating	Galvanized per ASTM A153/A123 (G), Bare Steel (NG), or Epoxy Coated per ICC-ES AC228 (EP)
Compatibility	MH313, MH313R, MH325, and MH325R

CAP CAPACITY	
Ultimate Compression / Tension	16 Tons / 16 Tons
Allowable Compression / Tension	8 Tons / 8 Tons

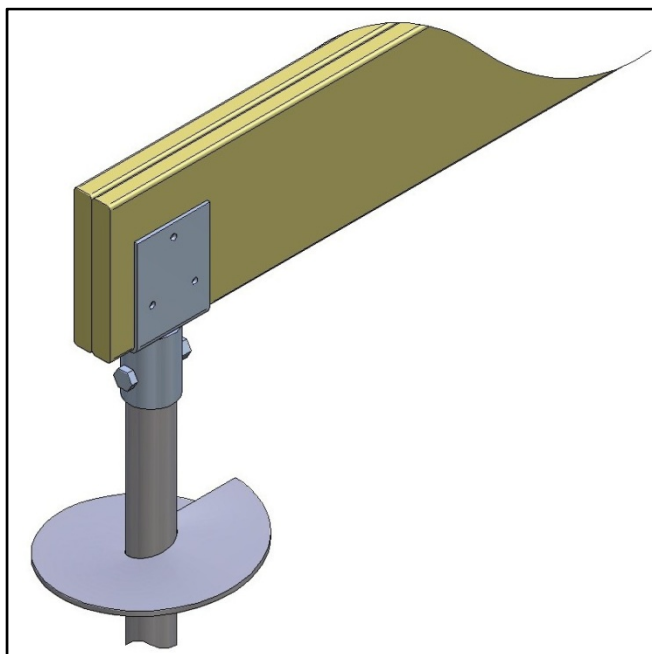
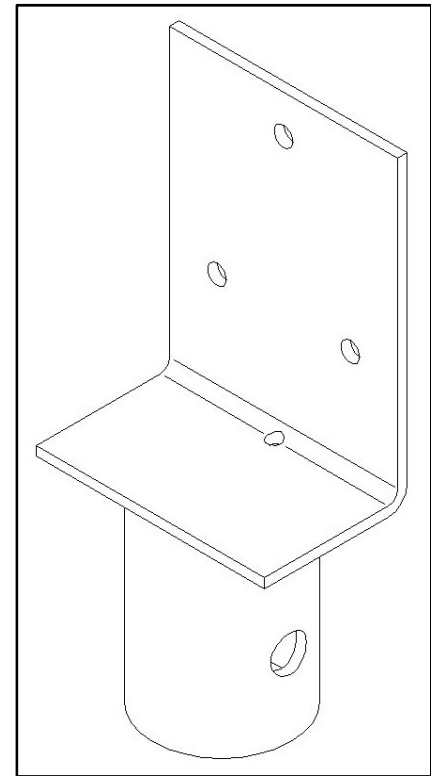

Installation Notes:

After installation of a Magnum Helical Pile to the correct depth, torque, and capacity, cut-off the pile shaft at the proper elevation. Drill 15/16" hole using Magnum drill template. Place the pile cap over the shaft and secure with 7/8" bolt. Snug tighten nut. Place wood beam on cap angle and secure with 1/2" lag screws as required for the project.

All Magnum Steel & Products Made in U.S.A.

Magnum Piering, Inc.

6082 Schumacher Park Dr.

West Chester, OH 45069

800-822-7437

www.magnumpiering.com

© Copyright 2010 Magnum Piering, Inc. All Rights Reserved.
U.S. Patents 6,058,662 and 5,234,287; Other Patents Pending.