

# MAGNUM<sup>®</sup> MHC1300-637 Bearing Plate Cap

Allowable Capacity 75 Tons Compression / 54 Tons Tension

5.72-Inch I.D. Collar with 10"x10"x5/8" Bearing Plate

Fits MH625 through MH646R Magnum<sup>®</sup> Helical Piles



## Description

Magnum MHC1300-637 bearing plate cap has 150 tons ultimate capacity, 75 tons working capacity in compression and 108 tons ultimate capacity, 54 tons working capacity in tension. The bearing plate cap consists of a collar tube with bolt hole for connection to Magnum helical piles and 10"x10"x5/8" plate for embedment in cast-in-place reinforced concrete. The bearing plate cap is designed in accordance with ICC-ES document AC358 as well as IBC, ACI, and AISC codes. Application of the cap varies by project and is the responsibility of registered design professional including minimum embedment for two-way and one-way punching shear, reinforcement of concrete, and pile spacing.

SPECIFICATIONS	
Collar Tube	0.3 in. x 5.72 in. I.D. ASTM A513 GR65+
End Effector	10"x10"x5/8" Steel Bearing Plate
Pile Connection	(3) 1.5" SAE Grade 5 / ASTM A325 Bolts
Surface Coating	Galvanized per ASTM A153/A123 (G), Bare Steel (NG), or Epoxy Coated per ICC-ES AC228 (EP)
Compatibility	MH625, MH625R, MH637, MH637R, MH646, and MH646R
CAP CAPACITY	
Ultimate Compression / Tension	150 Tons / 108 Tons
Allowable Compression / Tension	75 Tons / 54 Tons

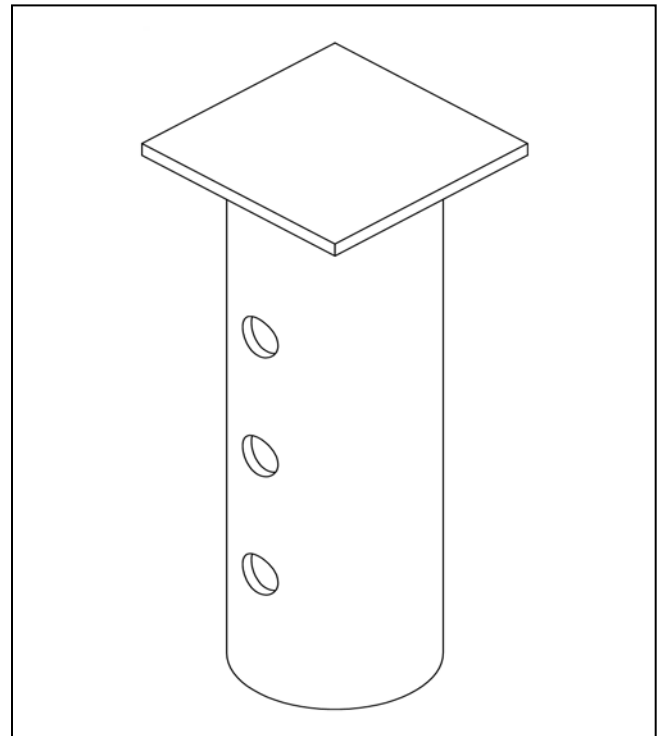

Application View Forthcoming

### Installation Notes:

After installation of a Magnum Helical Pile to the correct depth, torque, and capacity, cut-off the pile shaft at the proper elevation. Drill 25/16" holes using Magnum drill template. Place the pile cap over the shaft and secure with three 1.5" bolts. Snug tighten nuts. Place reinforcing steel as required for the project and cast concrete over and around the pile cap.

*All Magnum Steel & Products Made in U.S.A.*

### Magnum Piering, Inc.

6082 Schumacher Park Dr.

West Chester, OH 45069

800-822-7437

www.magnumpiering.com

© Copyright 2010 Magnum Piering, Inc. All Rights Reserved.  
U.S. Patents 6,058,662 and 5,234,287; Other Patents Pending.