

# MAGNUM<sup>®</sup> MHC1416-6 Tilted Plate Cap

## Allowable Capacity 95 Tons Compression / 73 Tons Tension

5.72-Inch I.D. Collar with 16"x16"x7/8" Bearing Plate Battered 20 deg  
Fits MH625 through MH646R Magnum<sup>®</sup> Helical Piles



### Description

Magnum MHC1416-6 bearing plate cap has 191 tons ultimate capacity, 95 tons working capacity in compression and 146 tons ultimate capacity, 73 tons working capacity in tension. The bearing plate cap consists of a collar tube with bolt holes for connection to Magnum helical piles and 16"x16"x7/8" plate battered 20 deg for attachment to a steel beam. The bearing plate cap is designed in accordance with ICC-ES document AC358 as well as IBC, ACI, and AISC codes. Application of the cap varies by project and is the responsibility of registered design professional including beam attachment, beam shear, beam span, web stiffening, bracing, and pile spacing as applicable.

SPECIFICATIONS	
Collar Tube	0.3 in. x 5.72 in. I.D. ASTM A513 GR65+
End Effector	16"x16"x7/8" Steel Bearing Plate Battered 20 deg
Pile Connection	(3) 1.5" SAE Grade 5 / ASTM A325 Bolts
Surface Coating	Galvanized per ASTM A153/A123 (G), Bare Steel (NG), or Epoxy Coated per ICC-ES AC228 (EP)
Compatibility	MH625, MH625R, MH637, MH637R, MH646, and MH646R

CAP CAPACITY	
Ultimate Compression / Tension	191 Tons / 146 Tons
Allowable Compression / Tension	95 Tons / 73 Tons

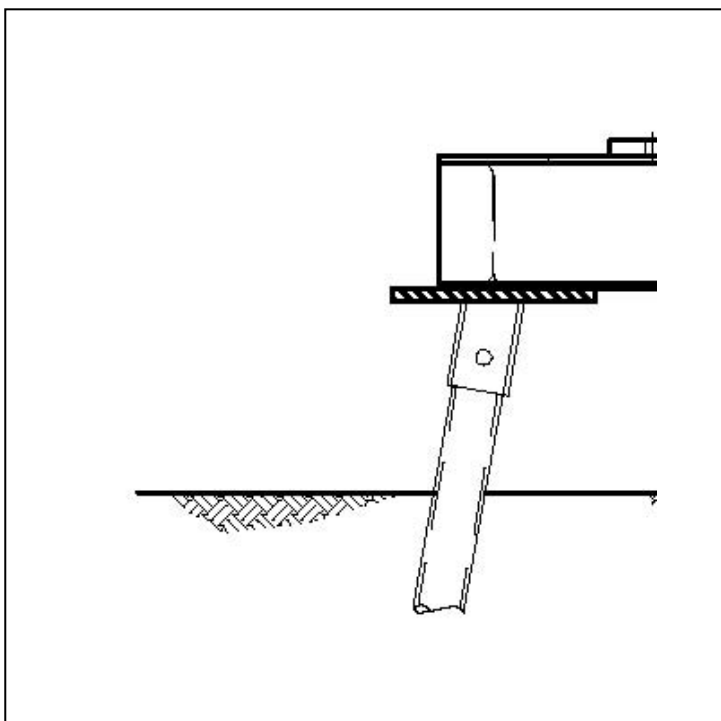
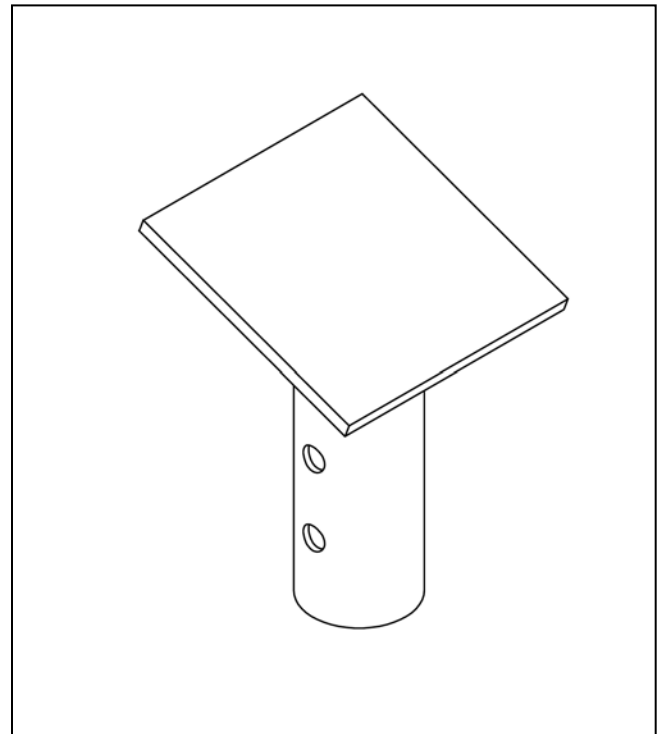

### Installation Notes:

After installation of a Magnum Helical Pile to the correct depth, torque, and capacity, cut-off the pile shaft at the proper elevation. For Bolted "B" application, drill three 25/16" holes using Magnum drill template. Place the pile cap over the shaft and secure with three 1.5" bolts. Snug tighten nuts. For Welded "W" application, plug weld cap in place through manufactured drill holes. Remove surface coating from plug weld areas. Place steel beam on cap and weld per project specifications.

*All Magnum Steel & Products Made in U.S.A.*

### Magnum Piering, Inc.

6082 Schumacher Park Dr.  
West Chester, OH 45069  
800-822-7437  
www.magnumpiering.com

© Copyright 2010 Magnum Piering, Inc. All Rights Reserved.  
U.S. Patents 6,058,662 and 5,234,287; Other Patents Pending.